

White Concrete for Aggressive Environment





Synopsis

This report documents the durability and strength of white concrete based on Aalborg White cement. The documentation is based on a large experimental examination in which the properties of white concrete have been compared with properties of reference concretes, which are today considered as well-known and well-documented concretes with great durability in an aggressive environment. The powder compositions of the reference concretes are similar to the concretes used for respectively the Great Belt Fixed Link and the Oresund Link in Denmark.

The overall conclusion of the examination is:

Concrete based on AALBORG WHITE® cement and silica fume has at least as good properties in respect to strength and durability as concrete normally used in constructions placed in an aggressive environment.

Aalborg Portland, September 2003



Contents:

- 1. Introduction 3
- 2. Concrete mix designs and fresh concrete properties 4
 - 2.1 Components 5
- 3. Strength properties 6
 - 3.1 Compressive strength 6
 - 3.2 Splitting tensile strength 8
 - 3.3 Modulus of elasticity 9
- 4. Adiabatic heat development 10
- 5. Frost testing and air void analysis 13
 - 5.1 Evaluation to SS137244 13
 - 5.2 Evaluation to DS 481 and ASTM 457-98 15
- 6. Chloride testing 16
 - 6.1 NT BUILD 492 16
 - 6.2 NT BUILD 443 19
 - 6.3 General discussion of chloride diffusion coefficient measurements 22
- 7. Conclusions 23
- 8. References 24

Appendices:

- Appendix A Concrete mix designs and fresh concrete properties
- Appendix B Compressive strength
- Appendix C Splitting tensile strength
- Appendix D Modulus of elasticity
- Appendix E Frost testing to SS137244 and the analysis of thin sections
- Appendix F Chloride testing according to NT BUILD 492
- Appendix G Chloride testing according to NT BUILD 443
- Appendix H Adiabatic heat development
- Appendix I Chloride profiles according to NT BUILD 443
- Appendix J Data for materials used



1. Introduction

Concrete possesses a wide range of exceptional properties, making it a unique building material. The most obvious advantages of concrete are its formability and great strength. An extra dimension is added when it is also possible to decide the colour. White cement can contribute to freedom of choice with respect to concrete colour.

Presently, white concrete has many applications, e.g. in facade elements and surface coverings, but white or coloured concrete is only used to a very limited extent for constructions that are cast in situ in aggressive environments. There is, however, increasing interest in using white or coloured concrete in such environments. The purpose of this report is to document the properties of white concrete in order to allow its use in aggressive environments.

One significant barrier, which often results in traditional grey concrete being chosen instead of white concrete, is the perception among decision-makers that white concrete is less durable than grey concrete. However, the chemical composition of white cement from Aalborg Portland made in Denmark is ideally suited for the production of concrete with high strength and durability.

On this background, an experimental programme was conducted to determine the strength and durability properties of white concrete. The mix designs included in the investigation were chosen to match state-of-the-art grey concretes. For comparison purposes, reference concretes with powder compositions similar to those used to build the Great Belt Bridge and Tunnel and the Øresund Link in Denmark were used. White silica fume powder and light-coloured blast furnace slag were used as pozzolans in the white concretes. As dirt repelling properties can also be a problem with white concretes, mix designs containing hydrophobic admixtures were also investigated.





2. Concrete mix designs and fresh concrete properties

Concretes were prepared in two series with water/powder ratios of 0.36 and 0.45 respectively. Reference concretes were prepared with powder compositions corresponding to those used to build the Great Belt Bridge and Tunnel (Ref. A) and the Øresund Link (Ref. B). The durability and other properties of white concretes in aggressive environments were compared with those of the reference concretes, which were assumed to be well-known, well-tested, highly durable concretes.

The paste composition of the concretes are shown in Table 1. For all concretes, the weight-percentage composition of aggregates was 38% pit sand 0/2 class E, 13% crushed granite 2/8 class E, and 49% marine rubble 8/16 class A; aggregate classes according to Danish Standard. The concretes had constant fractions of paste volume, aggregate skeleton and water content. Workability was adjusted by the addition of plasticiser and super-plasticiser to achieve a target slump of 150 mm. The target air content was 6%.

Besides the reference concretes, each series contained concretes with the following powder combinations:

- one concrete based on 100% Aalborg White (AW) with no other powder;
- one concrete based on 95% AW and 5% silica fume;
- one concrete based on 100% AW with 2 kg zinc stearate per m³ concrete;
- one concrete based on 95% AW and 5% silica fume with 2 kg zinc stearate per m³ concrete;
- one concrete based on 70% AW and 30% blast furnace slag.

An additional reference concrete (Ref. C) was included in series 2. Apart from having a higher water/powder ratio, Ref. C was identical to Ref. A in series 1. The designations and powder combinations of all concretes included in the investigation are shown in Table 2.

The concretes had a slump of 150±30 mm and an air content of 5.9-7.0%. It should be noted that there was no great effect of powder composition on slump or air content. However, it was necessary to double or triple the quantity of air-entraining agent used in the mix designs containing zinc stearate (i.e. hydrophobic agent). *

Table 1: Paste composition of concretes included in the investigation.

	water/powder ratio 0.36	water/powder ratio 0.45
Total powder content (kg/m ³)	391	333
Water content (kg/m ³)	140	150
Plasticiser (% of powder weight)	0.5	0.4
Super-plasticiser (% of powder weight)	0.5-0.8	-

Table 2: Powder composition of concretes included in the investigation.

Material	Series 1: water/powder ratio 0.36						Series 2: water/powder ratio 0.45						
	Ref. A	Mix 1	Mix 2	Mix 3	Mix 4	Mix 5	Ref. B	Ref. C	Mix 6	Mix 7	Mix 8	Mix 9	Mix 10
Low-alkali sulphate-resistant cement (%)	80						95	80					
Aalborg White cement (%)		95	100	95	100	70			95	100	95	100	70
Fly ash (%)	15							15					
White silica fume (%)		5		5					5		5		
Silica fume (%)	5						5	5					
White Blast furnace slag (%)						30							30
Zinc stearate(kg/m ³)				2	2						2	2	

* Zinc stearate is just one type of stearate among a large selection on the market. For example »Calcium stearate« has proven easy to use in the production, without influencing on the air content.



2.1 Components

Table 3 lists the components used to formulate the concretes investigated. Further documentation of several of the materials can be found in Appendix J.

Table 3: Description of individual concrete components.

Material	Type	Comments
Cement	Low-alkali, sulphate-resistant AALBORG WHITE®	See Appendix J for further details. See Appendix J for further details.
Sand	Nørre Halne 0-2 mm	See Appendix J for further details.
Stone	Espevig 2-8 mm Espevig 8-16 mm	See Appendix J for further details. See Appendix J for further details.
Fly-ash	NEFO	See Appendix J for further details.
Silica fume	Elkem Silica, grey White	Supplied by Elkem®. See Appendix J for further details.
Slag	White	See Appendix J for further details.
Plasticiser	Conplast 212 Peramin F	Water-reducing plasticiser based on lignosulphonate. Supplied by Fosroc®. Super-plasticiser based on melamine. Supplied by Fosroc®.
Air-entraining agent	Conplast 316 AEA 1:1	Air-entraining agent based on Vinsol and tenside. Supplied by Fosroc®.



3. Strength properties

The development of compressive strength, tensile strength and modulus of elasticity is shown in Appendices B-D where each value is the average of measurements made on three concrete cylinders. Results for compressive strength are shown both as actual values and values adjusted to an air content of 6% (it was assumed that a 1% difference in air content results in a 4% difference in compressive strength) (4).

Compressive strength was measured for all concretes at 1, 2, 7, 14, 28 and 90 days' maturity. Splitting tensile strength and modulus of elasticity were measured on Ref. A, Mix 1, Mix 2 and Mix 3 at 1, 2, 7, 14 and 28 days' maturity.

3.1 Compressive strength

3.1.1 Water/powder ratio of 0.36

Figure 1 shows the results of compressive strength tests on concretes with a water/powder ratio of 0.36 up to and including 90 days' maturity. The results are shown relative to Ref. A in Figure 2.

Figure 1 shows that AW-based concretes were generally stronger at early ages than the reference concrete (Ref. A), based on low-alkaline, sulphate-resistant cement. Furthermore, the figure shows that white concretes (Mix

1, Mix 2, Mix 3 and Mix 4) possessed strengths after 2 days that were higher than the strength achieved by the reference concrete after 7 days. Concretes containing zinc stearate (Mix 3 and Mix 4) had marginally lower compressive strengths than corresponding concretes without zinc stearate (Mix 1 and Mix 2). Addition of blast furnace slag (Mix 5) reduced initial compressive strength in relation to the other AW-based concretes, but initial compressive strength was still higher than the reference. Generally, strength develops more slowly in concretes incorporating blast furnace slag than in concretes based solely on Portland cement (5).

At 28 and 90 days' maturity the compressive strength of AW-based concretes was similar to that of the reference concrete. As expected, the compressive strength of AW-based concretes with 5% silica fume was greater than that of AW-based concretes without silica fume. The compressive strength of Mix 5, which contained 30% blast furnace slag, was as much as 12 MPa lower than that of Mix 2.

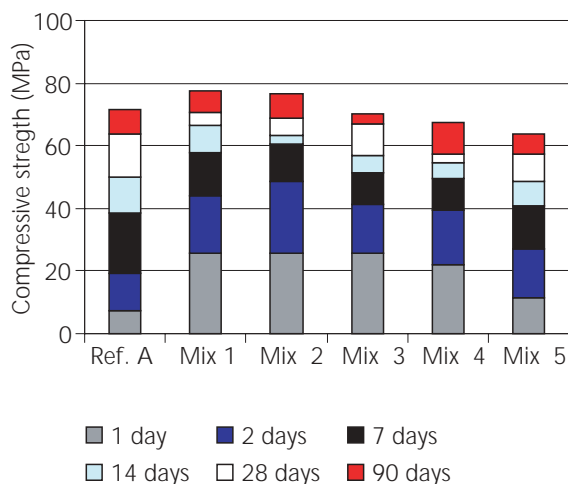

Figure 1: The compressive strength of concretes with a water/powder ratio of 0.36. Values adjusted to an air content of 6%.

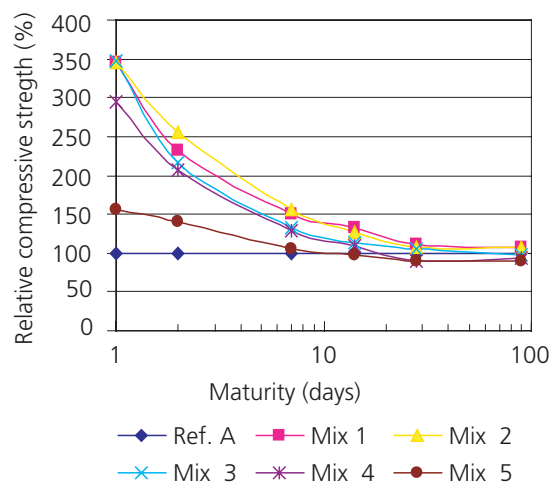

Figure 2: Relative compressive strength (Ref. A = 100) of concretes with a water/powder ratio of 0.36.



3.1.2 Water/powder ratio of 0.45

Figure 3 shows the results of compressive strength tests on concretes with a water/powder ratio of 0.45 up to and including 90 days' maturity. The results are shown relative to Ref. B in Figure 4.

Figure 3 shows that AW-based concretes were considerably stronger at early ages than the reference concrete (Ref. B). Furthermore, the figure shows that AW-based concretes possessed strengths after 2 days that were generally similar to the strength achieved by the reference concrete after 7 days. AW-based concretes with 5% silica fume possessed greater compressive strengths than pure AW concretes. Initially, concretes containing zinc stearate had compressive strengths similar to corresponding white concretes without zinc stearate.

At 28 days' maturity, a high level of compressive strength was attained by Ref. B. This level was similar to that achieved by AW concretes with 5% silica fume. The compressive strength of Mix 7, a pure AW concrete, was slightly lower. A large increase in compressive strength between days 14 and 28 was also evident for Ref. C, a concrete identical to Ref. A except for a higher water/powder ratio. The compressive strength of Mix 6 increased only slightly between days 14 and 28.

Between days 28 and 90, the compressive strength of Ref. B increased approx. 2 MPa. The compressive strength of all other concretes increased approx. 10 MPa during the same period. The compressive strength of Mix 10, containing 30% blast furnace slag, was significantly lower than that of the other concretes after 90 days.

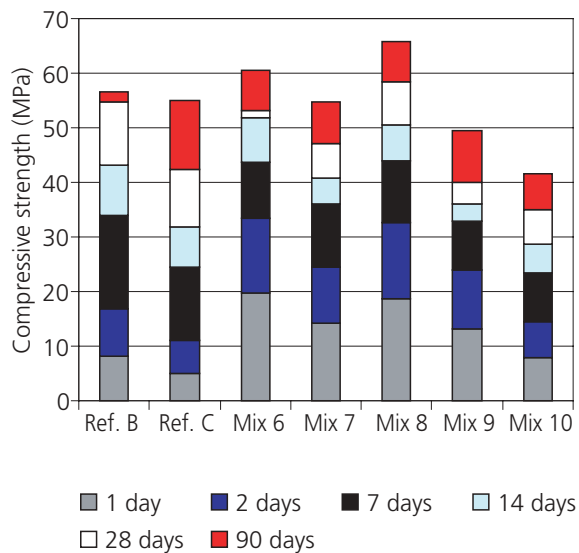

Figure 3: The compressive strength of concretes with a water/powder ratio of 0.45. Values adjusted to an air content of 6%.

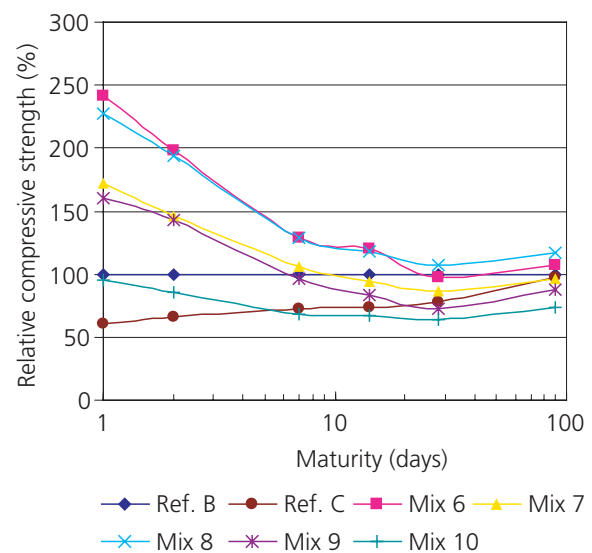

Figure 4: Relative compressive strength (Ref. B = 100) of concretes with a water/powder ratio of 0.45.



3.2 Splitting tensile strength

Splitting tensile strength was measured for Ref. A, Mix 1, Mix 2 and Mix 3. The measurement method is described below, and the results are shown in Figure 5.

Initially, splitting tensile strength was considerably higher for AW-based concretes than for the reference concrete. The splitting tensile strength of AW-based concretes after 2 days was similar to that of the reference concrete at 7 days.

After 14 days, all concretes had comparable splitting tensile strengths.

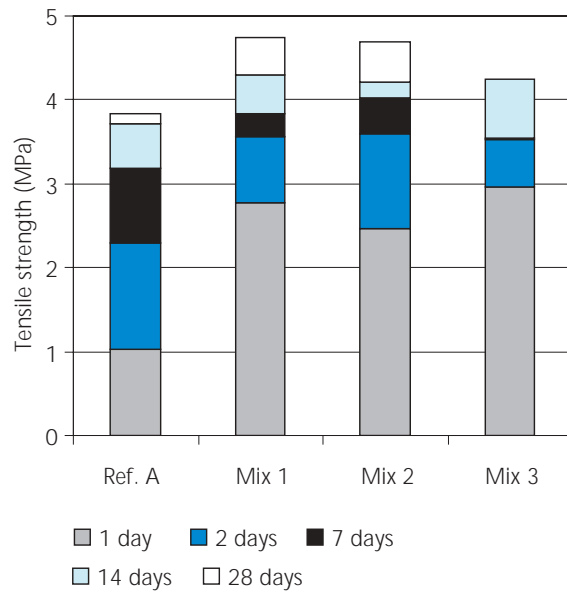

Figure 5: Splitting tensile strength measured at 1, 2, 7, 14 and 28 days' maturity. Splitting tensile strength was only measured for Ref. A, Mix 1, Mix 2 and Mix 3.

Splitting tensile strength

Splitting tensile strength was determined in accordance with Danish Standard DS 423.34. Tests are performed by placing concrete cylinders horizontally in a compression testing machine and then loading them along the longitudinal axis as shown in the illustration. At load P , tensile stress, τ , occurs in the vertical centre section perpendicular to the direction of the load (4). The splitting tensile strength can then be calculated from cylinder dimensions and the load necessary to fracture the cylinder.



3.3 Modulus of elasticity

As was the case for splitting tensile strength, the modulus of elasticity was measured only for Ref. A, Mix 1, Mix 2 and Mix 3. The measurement method is described below, and the results are shown in Figure 6.

The modulus of elasticity increased with time (in much the same way as splitting tensile strength) observing higher initial values for AW-based concretes than for the reference concrete, based on low-alkali, sulphate-resistant cement. The modulus of elasticity of AW-based concretes after 2 days was similar to that of the reference concrete after 7 days.

After 14 days, the modulus of elasticity of all concretes was similar.

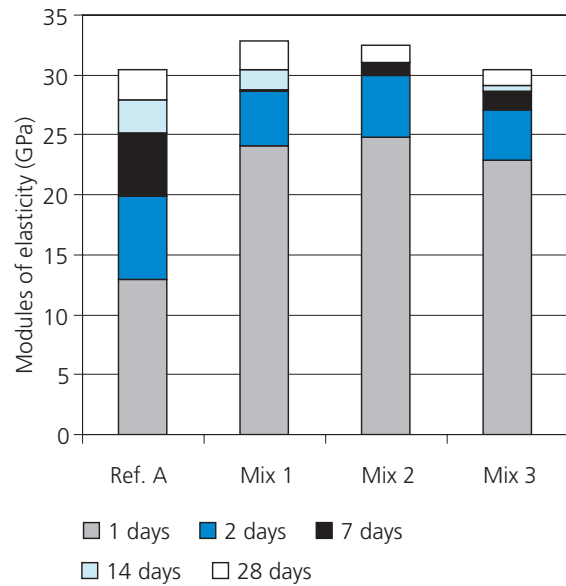
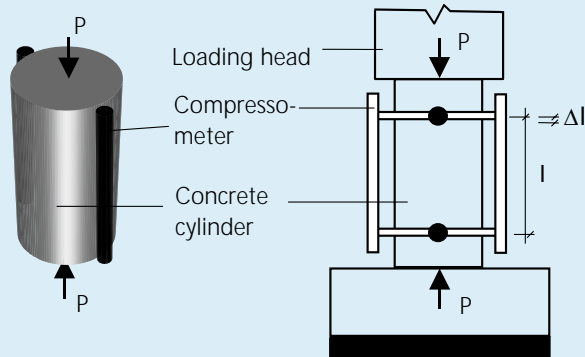

Figure 6: Modulus of elasticity measured at 1, 2, 7, 14 and 28 days' maturity. Modulus of elasticity was only measured for Ref. A, Mix 1, Mix 2 and Mix 3.

Modulus of elasticity

Modulus of elasticity was determined in accordance with Danish Standard DS 423.25. Measurements are performed by mounting concrete cylinders in a compressometer capable of recording deformation. The cylinders are then deformed by loading, and curves relating load values to the corresponding relative deformation, or strain as it is also known ($\Delta l/l$), are generated. The modulus of elasticity is then determined as the tangent to the initial slope of the generated curve.





4. Adiabatic heat development

Adiabatic calorimeter measurements were performed on all concretes and the *Freiesleben model* (2) was fitted to the results. The parameters for the model are shown in Appendix H together with heat development diagrams. Property parameters were determined from a single measurement on each concrete. The measurement method is described below.

Adiabatic heat development

During curing, heat of hydration causes the temperature of concrete to increase. In adiabatic calorimetry, this temperature increase is measured in a sample which is prevented from exchanging heat with its surroundings.

Heat exchange with the surroundings is prevented in an adiabatic calorimeter by insulating the sample within a series of chambers. With a multi-chambered calorimeter, heat exchange with the surroundings can be limited to extremely low levels by regulating the temperature in the outermost chamber. Thus, approximate adiabatic conditions can be achieved, and these have proved to be in close agreement with the heat generated in actual concrete sections. The principle of an adiabatic calorimeter with a single chamber is shown in the figure below.

Results for heat development are plotted against the corresponding maturity of the concrete on a single logarithmic scale as shown in the diagram below. The following function is then fitted to the values:

$$Q(M)=Q_{\infty} \cdot \exp \left[-\left(\frac{\tau_e}{M} \right)^{\alpha} \right]$$

Where $Q(M)$ is the heat developed (kJ/kg cement) at maturity M , Q_{∞} is the final heat generated, τ_e is a characteristic time constant (h), M is the maturity of the concrete (h), and α is a curvature parameter (-). The function is empirical and was developed by P. Freiesleben Hansen in the 1970's (2) (3).



4.1 Water/powder ratio of 0.36

The adiabatic heat development of concretes with a water/powder ratio of 0.36 is shown in Figure 7 and the corresponding property parameters are shown in Table 4.

At early hydration stages white concretes generated more heat, measured in kJ/kg powder, than the reference concrete. This can be seen from the fitted parameter τ_e , which was almost twice as high for Ref. A as for the white concretes.

Concretes mainly based on AW (Mix 1, Mix 2, Mix 3 and Mix 4) had significantly higher final heat levels than Ref. A, which was based on low-alkali, sulphate-resistant cement. The final heat developed by these AW-based concretes was approx. 50 kJ/kg powder higher than for Ref. A. It should be noticed that Ref. A contains less cement per m³ than Mix 1 - 4.

Replacing 30% of the cement with blast furnace slag (Mix 5) reduced final heat by some 30 kJ/kg powder. The rate of heat development for Mix 5 decreased at early ages to a level between the white concretes and Ref. A.

The addition of zinc stearate did not influence heat development.

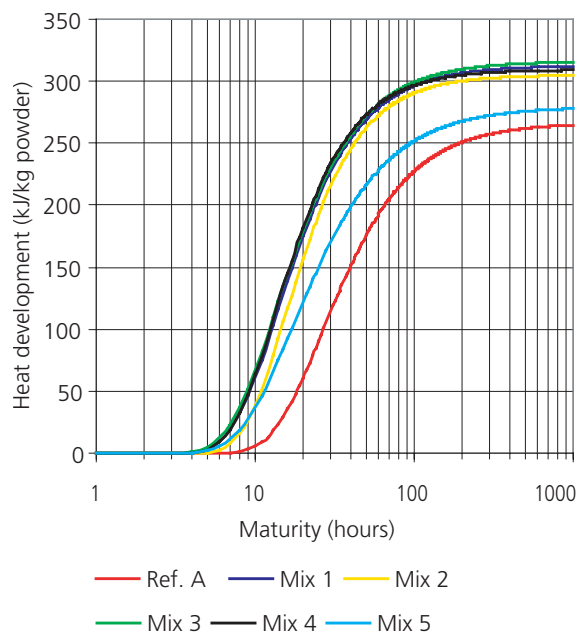

Figure 7: Adiabatic heat development of concretes with a water/powder ratio of 0.36.

Table 4: Property parameters describing adiabatic heat development.

	Ref. A	Mix 1	Mix 2	Mix 3	Mix 4	Mix 5
Q_{∞} , (kJ/kg powder)	266.4	312.5	305	316	309.3	279.4
τ_e , (h)	26.5	13.9	15.6	13.5	13.4	17.3
α , (-)	1.39	1.49	1.63	1.45	1.58	1.29



4.2 Water/powder ratio of 0.45

The adiabatic heat development of concretes with a water/powder ratio of 0.45 is shown in Figure 8 and the corresponding property parameters are shown in Table 5.

At early hydration stages, white concretes (Mix 6, Mix 7, Mix 8 and Mix 9) generated more heat, measured in kJ/kg powder, than Ref. B and Ref. C. As found with a water/powder ratio of 0.36, heat development in a white concrete containing blast furnace slag (Mix 10) was reduced at early ages.

Similar final heat levels were found for Mix 6, Mix 7, Mix 8, Mix 9, Ref. B and Ref. C. The final heat level for Mix 10 was lower than for the other concretes.

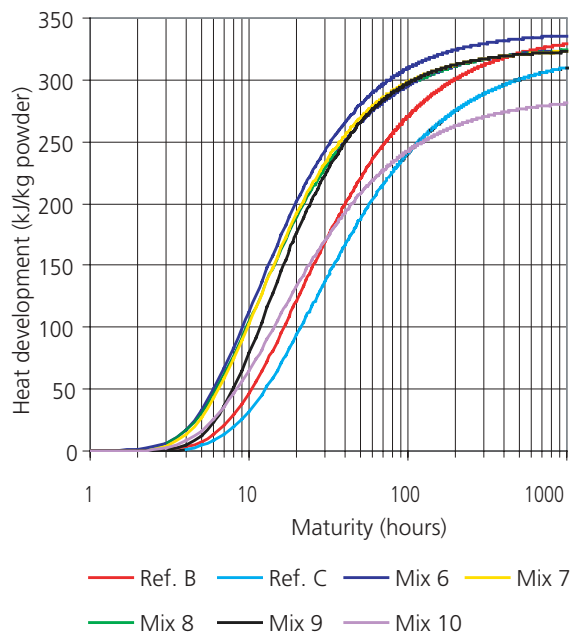

Figure 8: Adiabatic heat development of concretes with a water/powder ratio of 0.45.

Table 5: Property parameters describing adiabatic heat development.

	Ref. B	Ref. C	Mix 6	Mix 7	Mix 8	Mix 9	Mix 10
Q_{∞} (kJ/kg powder)	337.3	321.5	338.3	326.9	325.1	324.4	286.3
$\tau_{e'}$ (h)	20.4	25.2	10.9	11.3	11.3	13.3	15.1
α , (-)	0.95	0.9	1.09	1.05	1.12	1.21	0.95



5. Frost testing and air void analysis

The frost resistance of the concretes was investigated by measuring the degree of scaling of concrete samples in accordance with Swedish Standard SS137244 and by analysing thin sections and evaluating them in accordance with Danish Standard DS 481 and ASTM C 457-98. The experimental results are shown in Appendix E where the results of tests according to SS137244 are the average of measurements made on four samples, while the results of evaluations to DS 481 and ASTM 457-98 are obtained from measurement on a single section.

5.1 Evaluation according to SS137244

The method used to measure the frost resistance of concrete according to SS137244 is shown below.

Evaluation of frost resistance according to SS137244

Investigation of concrete frost resistance was performed according to SS137244. In this method, concretes of 28 days' maturity are subjected to 24-hour freeze-thaw cycles with temperatures fluctuating between -20°C and +20°C. The concrete is cast as a 15 x 30 cm cylinder from which three 50 mm discs are cut. The discs are mounted in a rubber ring insulated with polystyrene (see illustration) and a 3% salt solution is poured onto the free concrete surface before subjecting the entire sample to freeze-thaw cycles. After a certain number of cycles (typically 7, 14, 28, 42 and 56), the amount of material scaled from the concrete surface is weighed before returning the sample to the freeze-thaw environment until the next measurement date.

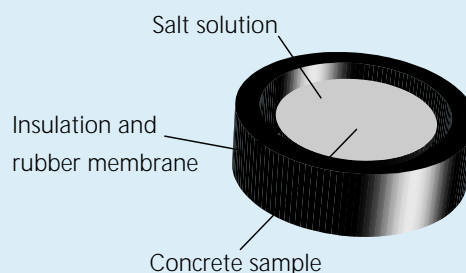

SS137244 stipulates that the frost resistance of concrete can be evaluated as »very good«, »good«, »acceptable« or »unacceptable« on the basis of the following criteria:

Frost resistance		Requirements
Very good	VG	Average scaling after 56 cycles < 0,1 kg/m ²
Good	G	Average scaling after 56 cycles < 0,2 kg/m ² or Average scaling (AS) after 56 days < 0,5 kg/m ² and $AS_{56}/AS_{28} < 2$
Acceptable	A	Average scaling (AS) after 56 cycles < 1,0 kg/m ² and $AS_{56}/AS_{28} < 2$
Unacceptable	UA	The above requirements are not met



5.1.1 Water/powder ratio of 0.36

The results of frost resistance tests on concretes with a water/powder ratio of 0.36 are shown in Figure 9. All concretes with a water/powder ratio of 0.36 could be classified as very good, and the results confirm, that frost resistance is not a problem in concretes with a low water/powder ratio. Apparently, silica fume does not improve the frost resistance of concrete with a low water/powder ratio.

The frost resistance of all concretes with a water/powder ratio of 0.36 was therefore deemed comparable.

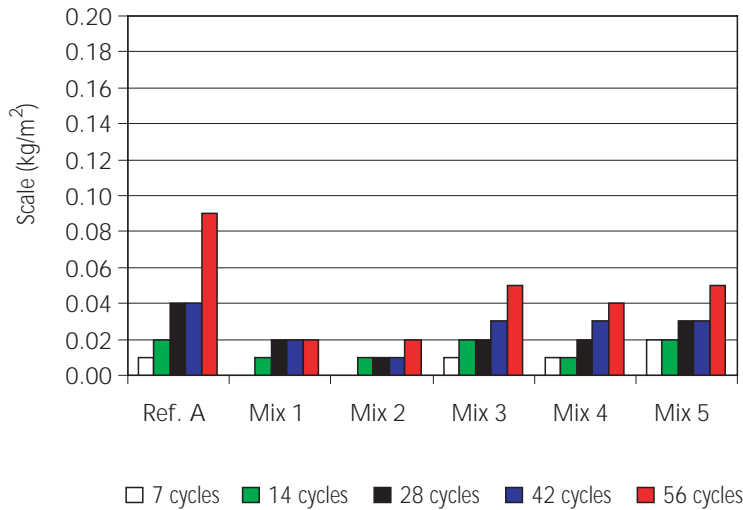

Figure 9: The quantity of material scaled from concretes with a water/powder ratio of 0.36 in frost resistance tests.

5.1.2 Water/powder ratio of 0.45

The results of frost resistance tests on concretes with a water/powder ratio of 0.45 are shown in Figure 10. Most concretes were frost resistant, and the amount of scaled material was generally very low. However, Mix 10, a concrete containing blast furnace slag, had low frost resistance, suggesting that slag concretes can be susceptible to frost damage when their water/powder ratio is high. Mix 7, a concrete based on 100% AW,

scaled more than Mix 9, a similar concrete with zinc stearate. This suggests that improved frost resistance can be achieved in concretes with high water/powder ratios by the addition of hydrophobic admixtures. Apparently, the addition of silica fume can improve the frost resistance of concretes with a high water/powder ratio (compare Mix 6 and Mix 7).

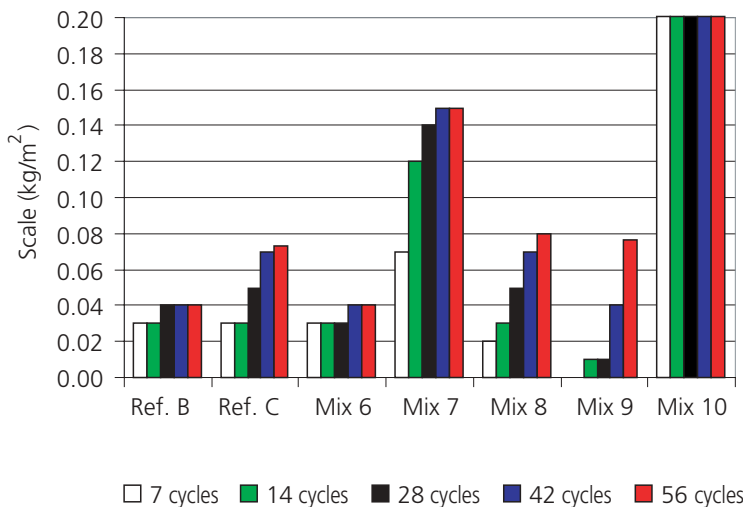

Figure 10: The quantity of material scaled from concretes with a water/powder ratio of 0.45 in frost resistance tests.



5.2 Evaluation to DS 481 and ASTM 457-98

Concrete frost resistance was also investigated by assessing thin sections according to DS 481 and ASTM C 457-98 in relation to the requirements shown in Table 6.

The results of the air void tests are shown in Appendix E.

Table 6: Frost resistance requirements for cured concrete according to DS 481 and ASTM C 457-98.

	DS 481	ASTM C 457-98
Specific surface (mm ⁻¹)	-	> 24
Spacing factor (-)	< 0.2	< 0.2
Paste air content (%)	> 10	-
Total air content (%)	-	-

5.2.1 Water/powder ratio of 0.36

The results are shown in Table 7. In relation to ASTM requirements, the specific surface of Ref. A, Mix 2 and Mix 5 was too low, while the spacing factor was too high for Mix 2 and Mix 5. All concretes had an acceptable paste air content.

It is surprising that almost all concretes with a water/powder ratio of 0.36 could not meet air void analysis requirements despite the fact that they achieved very good ratings for frost resistance according to SS137244. The usefulness of the standard requirements listed in Table 6 must therefore be questioned.

Table 7: Thin section analysis results for concretes with a water/powder ratio of 0.36.

Parameter		Ref. A	Mix 1	Mix 2	Mix 3	Mix 4	Mix 5
Specific surface	mm ⁻¹	23.7	25.7	15.4	32.1	29.0	19.3
Spacing factor	mm	0.19	0.17	0.27	0.14	0.16	0.24
Paste air content	%	17.0	18.3	20.5	16.9	17.5	15.7
Air content	%	5.7	6.1	6.8	5.5	5.7	5.1

5.2.2 Water/powder ratio of 0.45

The results are shown in Table 8. All concretes with a water/powder ratio of 0.45 met the requirements for specific surface and spacing factor. Furthermore, all concretes had an acceptable paste air content. Mix

10 thus met the requirements of the air void analysis despite being unable to meet the scaling requirements of SS137244.

Table 8: Thin section analysis results for concretes with a water/powder ratio of 0.45.

Parameter		Ref. B	Ref. C	Mix 6	Mix 7	Mix 8	Mix 9	Mix 10
Specific surface	mm ⁻¹	30.3	29.4	33.3	33.8	34.0	39.8	32.4
Spacing factor	mm	0.13	0.13	0.13	0.13	0.15	0.11	0.14
Paste air content	%	21.4	23.0	17.6	17.9	13.7	19.8	17.9
Air content	%	7.0	7.8	5.6	5.7	4.2	5.8	5.7



6. Chloride testing

The chloride resistance of the concretes was tested according to NT BUILD 492 and NT BUILD 443.

6.1 NT BUILD 492

NT BUILD 492 (known as the CTH-method) describes a method for determining the chloride diffusion coefficient of concrete at a given maturity. Diffusion coefficients were measured by the CTH method on all concretes at 28 days' maturity and for some concretes at 56 and 180 days' maturity. The results are shown in Appendix F where the values presented are the average of results achieved for three discs cut from a single concrete cylinder.

Measurement of chloride diffusion coefficient according to NT BUILD 492 (CTH method)

A 10 x 20 cm concrete cylinder is used in the CTH method. It is divided into three sections, thus providing three results which are then averaged. Individual concrete discs are lined with rubber and placed in an experimental set-up (see illustration below) in which one end of the disc is in contact with an anolyte (0.3 M Na/K(OH) solution) and the other is in contact with a catholyte (10% NaCl in 0.1 mol Na/K(OH) solution). A potential is then established between an anode im-

mersed in the anolyte and a cathode immersed in the catholyte. The potential is typically 30 V, and it is applied for approximately 24 hours. After exposure, the concrete disc is split longitudinally and the depth to which chloride has penetrated into the sample is determined by the application of silver nitrate solution which colours areas containing chloride ions red. The chloride diffusion coefficient can then be calculated from the penetration depth, the exposure time and the applied potential as described in NT BUILD 492.

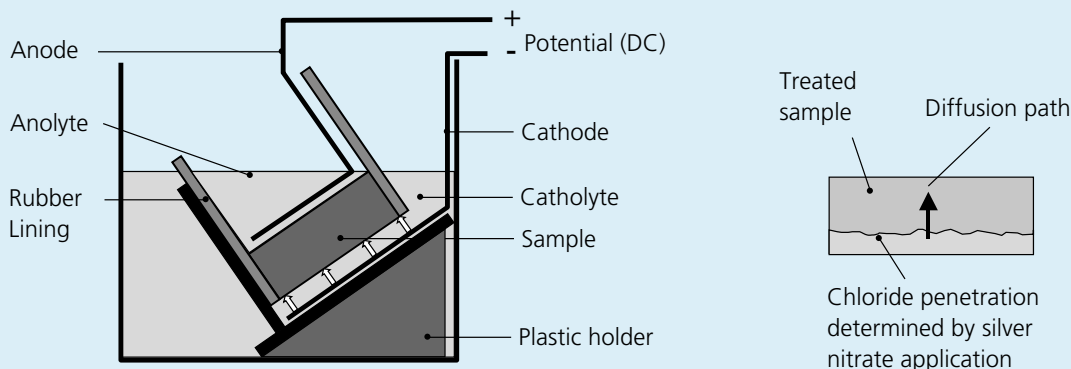

The limits used for evaluating the degree of chloride penetration resistance of concrete on the basis of results obtained from tests using the CTH method are shown in Table 9.

Table 9: Limits used for evaluating the degree of chloride penetration resistance of concrete on the basis of results obtained from tests using the CTH method.

Diffusion coefficient	Resistance to chloride penetration
$< 2 \times 10^{-12} \text{ m}^2/\text{s}$	Very good
$2 - 8 \times 10^{-12} \text{ m}^2/\text{s}$	Good
$8 - 16 \times 10^{-12} \text{ m}^2/\text{s}$	Acceptable
$> 16 \times 10^{-12} \text{ m}^2/\text{s}$	Unacceptable



6.1.1 Water/powder ratio of 0.36

The results of tests to determine chloride diffusion coefficients of concretes with a water/powder ratio of 0.36 are shown in Figure 11.

Figure 11 shows that the diffusion coefficients of AW-based concretes with 5% silica fume (Mix 1 and Mix 3) were comparable with that of the reference concrete (Ref. A). Diffusion coefficients of Mix 2 and Mix 4, which were based solely on AW, were high in comparison with the diffusion coefficients of concretes containing silica fume. Diffusion coefficients of concretes with zinc stearate (Mix 3 and Mix 4) were comparable with those of corresponding AW-based concretes without zinc stearate (Mix 1 and Mix 2).

Replacing 30% of the white cement with blast furnace slag (Mix 5) reduced the diffusion coefficient of the concrete in relation to 100% AW (Mix 2). The ability of the slag to bind chloride ions lies in its relatively high aluminium content. A more pronounced effect of blast furnace slag is expected in concrete of greater maturity

given its relatively slow reaction in comparison with Portland cement.

In relation to the limits described in Table 9, Ref. A, Mix 1, Mix 3 and Mix 5 had good resistance to chloride penetration at 28 days' maturity. At the same age, the chloride penetration resistance of Mix 2 and Mix 4 can be described as acceptable. As expected, Figure 11 shows that diffusion coefficients are lower (i.e. resistance to penetration is higher) in more mature concretes. This is because the concrete structure becomes increasingly non-porous in the binder phase as hydration progresses. At 56 days' maturity, diffusion coefficients of Ref. A and Mix 1 were halved in relation to that 28 days' maturity, and were thus close to being classified as having *very good* chloride penetration resistance. The resistance of Mix 2 was improved to *good* at 56 days' maturity, and the same tendency was found for Mix 3 at 180 days' maturity.

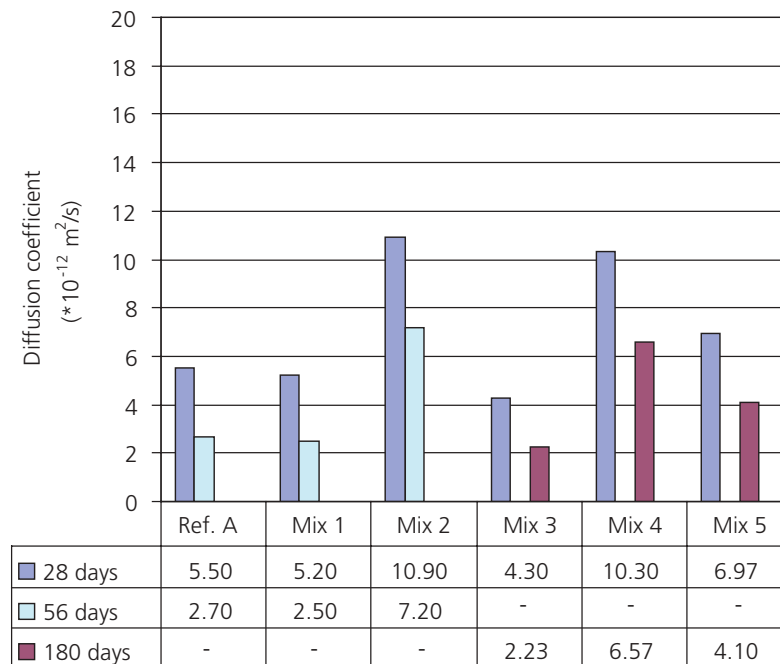

Figure 11: Chloride diffusion coefficients of concretes with a water/powder ratio of 0.36 measured using the CTH method.



6.1.2 Water/powder ratio of 0.45

The results of tests to determine chloride diffusion coefficients of concretes with a water/powder ratio of 0.45 are shown in Figure 12.

The diffusion coefficients of AW-based concretes with 5% silica fume (Mix 6 and Mix 8) were lower than that of Ref. B, supporting the theory that acceptable resistance to chloride penetration can be achieved by the addition of silica fume to AW-based concretes. In concretes without silica fume (Mix 7 and Mix 9) diffusion coefficients were higher than that of Ref. B.

The addition of zinc stearate (Mix 8 and Mix 9) apparently resulted in slightly higher diffusion coefficients than in the corresponding concretes without zinc stearate (Mix 6 and Mix 7). It should be noted that the effect of zinc stearate was the opposite in concretes with a water/powder ratio of 0.36.

The diffusion coefficient of Ref. B was comparable to that of Ref. C, which was an identical concrete to Ref. A but with a higher water/powder ratio.

Substituting 30% of the cement with blast furnace slag (Mix 10) slightly reduced the diffusion coefficient in relation to pure AW (Mix 7).

In relation to the limits described in Table 9, white concretes with Silica fume showed good resistance to chloride penetration at 28 days' maturity. The resistance to chloride penetration for all other concretes, with the exception of Mix 9, could be characterised as *acceptable*. As found for concretes with a water/powder ratio of 0.36, resistance was improved at increased maturity. For Mix 6 and Mix 10, diffusion coefficients were significantly reduced at increased maturity, while the diffusion coefficient of Mix 7 was only marginally lower at day 56 than at day 28.

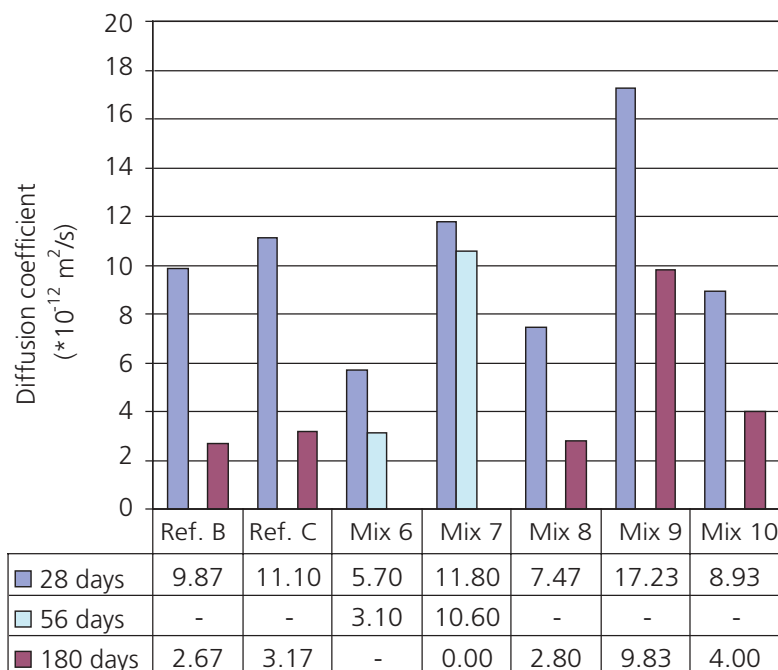

Figure 12: Chloride diffusion coefficients of concretes with a water/powder ratio of 0.45 measured using the CTH method.



6.2 NT BUILD 443

NT BUILD 443 describes a method for determining chloride profiles in concretes at a given maturity. Chloride diffusion coefficients and surface chloride concentrations can be determined from these profiles. Concretes to be tested are cast in 20 x 20 x 20 cm blocks and allowed to cure for 28 days at 20°C. The blocks are then cut in two and immersed in a 16.5% NaCl solution for 35 and 180 days. Fitted diffusion coefficients and surface chloride concentrations according to NT BUILD 443 for the concretes tested are shown in Appendix G where diffusion coefficient values are the average of two measurements on a single concrete sample.

Determination of chloride profiles according to NT BUILD 443

In order to determine the chloride profile of a concrete at a specific maturity, a 20 x 20 x 20 cm block is cast. At 28 days' maturity, the block is halved and placed in a 16.5% NaCl solution. After a certain exposure time, the block is removed from the salt solution and a 75 mm diameter hole is ground into it to a depth of about 14 mm from the cut surface. The hole is ground in steps of 1-2 mm, see the illustration below. For each layer, ground material is vacuumed

from the hole and stored in a plastic bag. The material is subsequently analysed for *Cl* and *CaO* contents. It is thus possible to construct a chloride profile for the concrete over the depth to which the hole was ground. The *CaO* concentration at specific depths shows the variation in paste concentration. The chloride diffusion coefficient can then be calculated from the measured chloride profiles (see NT BUILD 443).

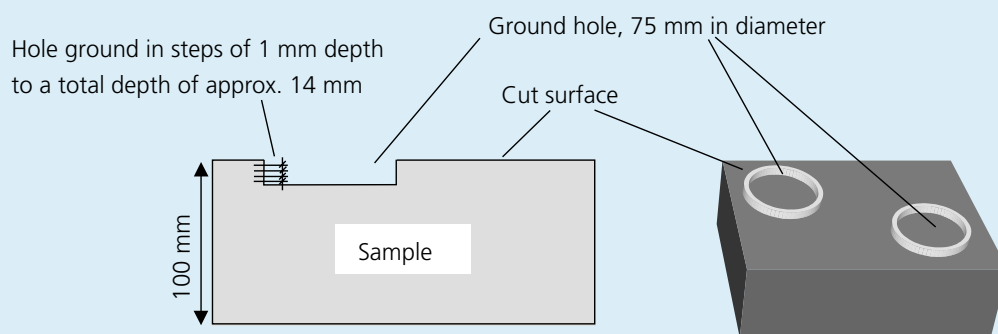

The chloride profiles are shown in Appendix I; there was only a slight variation in the CaO concentration through the sections. Conclusions can therefore be based exclusively on diffusion coefficients and surface concentrations.



6.2.1 Water/powder ratio of 0.36

Chloride diffusion coefficients determined from measured chloride profiles for concretes with a water/powder ratio of 0.36 are shown in Figure 13. The diffusion coefficients showed the same tendencies as found with the CTH method. However, diffusion coefficients were generally slightly lower.

The diffusion coefficients of concretes containing silica fume (Mix 1 and Mix 3) were comparable with that of Ref. A. The diffusion coefficients of white concretes containing no silica fume (Mix 2 and Mix 4) were considerably higher than that of Ref. A, and thus also than those of white concretes containing silica

fume. These concretes had flat *Cl* profiles, low surface concentrations and deep penetration, see Appendix I.

The addition of zinc stearate (Mix 3 and Mix 4) had little effect in comparison with corresponding concretes without zinc stearate (Mix 1 and Mix 2).

The diffusion coefficient of the concrete in which 30% of the AW cement was replaced by blast furnace slag (Mix 5) was lower than that of the pure AW concrete (Mix 2) but higher than that of Ref. A. As previously mentioned, blast furnace slag increases the binding of chloride ions in the binder phase.

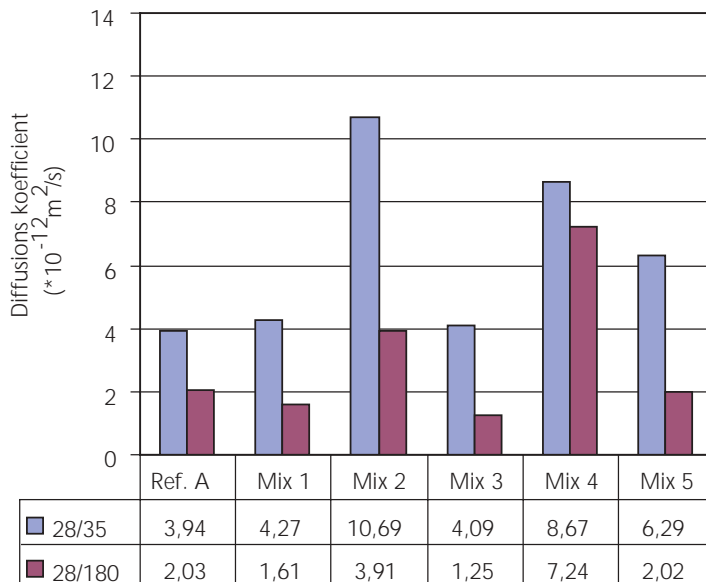

Figure 13: Chloride diffusion coefficients of concretes with a water/powder ratio of 0.36 as determined from chloride profiles measured using the NT Build 443.

xx/yy = days of maturity before exposure/days of exposure.



6.2.2. Water/powder ratio of 0.45

Chloride diffusion coefficients determined from measured chloride profiles for concretes with a water/powder ratio of 0.45 are shown in Figure 14.

The diffusion coefficients of white concretes containing silica fume (Mix 6 and Mix 8) were comparable to that of Ref. B. As with a water/powder ratio of 0.36, the diffusion coefficients of concretes containing no silica fume (Mix 7 and Mix 9) were relatively high in comparison with the corresponding concretes containing silica fume (Mix 6 and Mix 8).

The diffusion coefficient of Ref. C was slightly lower than that of Ref. B. This indicates that the fly ash included in Ref. C has only limited effect on the binding of chloride ions in comparison with the densifying effect of silica fume.

The diffusion coefficient of Mix 10 was comparable to those of Ref. B and Mix 6.

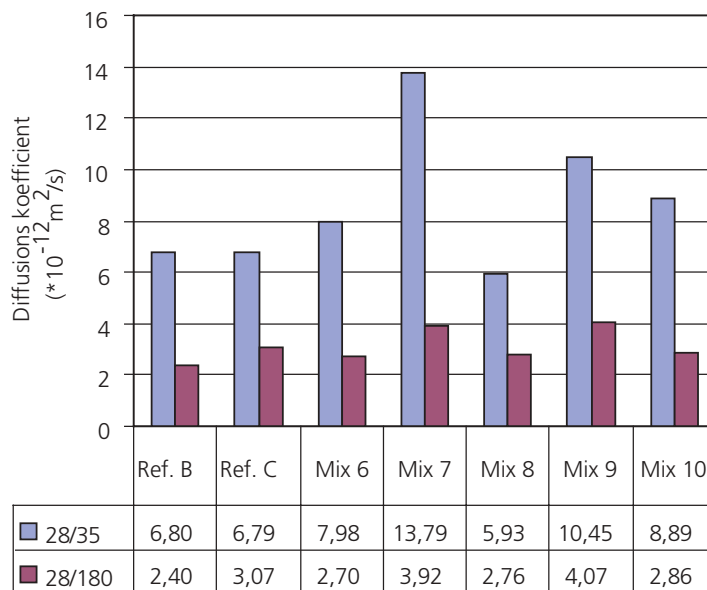

Figure 14: Chloride diffusion coefficients of concretes with a water/powder ratio of 0.45 as determined from chloride profiles measured using NT Build 443.

xx/yy = days of maturity before exposure/days of exposure.



6.3 General discussion of chloride diffusion coefficient measurements

In conclusion, white concretes with 5% silica fume achieve chloride diffusion coefficients that are comparable to the reference concretes. Silica fume helps densify the concrete and thus contributes to a lower diffusion coefficient. Similar effects of silica fume on the chloride diffusion coefficient of concrete paste have previously been reported (1).



7. Conclusions

1. The ultimate strength of white concretes was similar to that of the reference concretes at both investigated water/powder ratios.
2. The initial strength of white concretes was higher than that of the reference concretes.
3. The initial heat development in white concretes without blast furnace slag was higher than that of the reference concretes.
4. Replacing 30% of Aalborg White cement with blast furnace slag reduced heat development in relation to concretes based mainly on pure Aalborg White cement.
5. Chloride diffusion coefficients similar to those of reference concretes were achieved by the addition of 5% silica fume.
6. The addition of zinc stearate did not affect the measured properties significantly.
7. All concretes were frost resistant, with the exception of Mix 10, containing 30% blast furnace slag and having a water/powder ratio of 0.45.

The overall conclusion of the examination is:
Concrete based on AALBORG WHITE® cement and silica fume has at least as good properties in respect to strength and durability as concrete normally used in constructions placed in an aggressive environment



8. References

- (1) Byfors, K. (1987) Influence of silica fume and flyash on chloride diffusion and pH values in cement paste. *Cement and Concrete Research*, Vol. 17, 115-130.
- (2) Hansen, P. F. & Pedersen, E. J. (1978) *SBI-anvisning 125: Vinterstøbning (Winter casting)*. Danish Building Research Institute, Glostrup (in Danish).
- (3) Hansen, P. F. (1978) *Hærdeteknologi II (Curing technology II)*. Aalborg Portland & BKF-centralen, Aalborg (in Danish).
- (4) Herholdt, A. D. et al. (1985) *Beton-bogen (The Concrete Book)*. Aalborg Portland, CtO, Aalborg (in Danish).
- (5) Hewlett, P. C. et al. (1998) *Lea's chemistry of cement and concrete*. Arnold Publishers, New York.



Appendix A: Concrete mix designs and fresh concrete properties

	Ref. A	Serie 1, w/p - 0.36					Serie 2, w/p - 0.45						
		Mix 1	Mix 2	Mix 3	Mix 4	Mix 5	Ref. B	Ref. C	Mix 6	Mix 7	Mix 8	Mix 9	Mix 10
Low-alkali sulphate-resistant cement	312						316	266					
Aalborg White Cement		371	390	371	390	273			316	333	316	333	233
Fly ash	59							50					
White silica fume		20		20			17	17	17	17			
Silica fume	20												
Blast furnace slag						117							100
Zinc stearate				2	2						2	2	

Water	140	140	140	140	140	140	150	150	150	150	150	150	150
Sand	663	670	669	671	669	669	678	679	681	676	677	673	679
Stone 2/8	227	229	229	230	229	229	232	232	233	231	232	230	232
Stone 8/16	855	864	862	865	863	863	874	876	878	872	873	868	875
Plasticiser	2.00	2.00	2.00	2.00	2.00	2.00	1.40	1.00	0.50	1.00	1.30	1.20	1.00
Superplasticiser	2.70	1.50	1.50	1.50	1.50	1.50	-	-	-	-	-	-	-
Air-entraining agent	0.30	0.19	0.20	0.36	0.42	0.26	0.24	0.20	0.20	0.40	0.40	0.45	0.18
w/p-ratio	0.36	0.36	0.36	0.36	0.36	0.36	0.45	0.45	0.45	0.45	0.45	0.45	0.45
Eqv. w/p-ratio*	0.37	0.34	0.34	0.36	0.42	0.42	0.43	0.43	0.45	0.43	0.45	0.46	0.53

*Activity factor: Silica fume: 2; fly ash: 0.5

Concrete mix design

Slump	140	150	160	160	160	170	130	120	170	160	140	120	170
Air content	6.2	6.2	5.9	7.0	6.7	6.9	6.5	6.1	6.9	6.7	5.5	6.9	6.8
Density	2255	2260	2281	2240	2255	2240	2244	2230	2228	2235	2263	2235	2228
Density. 1 day	2287	2301	2340	2296	2303	2313	2261	2250	2260	2295	2291	2265	2254
Proctor probe	13h17m	9h17m	7h35m	6h50m	9h07m	9h40m	7h46m	4h52m	5h02m	4h58m	5h28m	10h22m	6h25m
Bleeding	0.0	0.0	6.0	0.0	4.3	0.0	1.8	1.2	0.0	6.2	3.0	9.0	15.0
Adiabatic heat development	266.4	312.5	305.0	316.0	309.3	279.4	337.3	321.5	338.3	326.9	325.1	324.4	286.3
τ	26.5	13.9	15.6	13.5	13.4	17.3	20.4	25.2	10.9	11.3	11.3	13.3	15.1
α	1.39	1.49	1.63	1.45	1.58	1.29	0.95	0.90	1.09	1.05	1.12	1.21	0.95

Fresh concrete properties



Appendix B: Compressive strength

	Series 1, w/p - 0.36					Series 2, w/p - 0.45						
	Ref. A	Mix 1	Mix 2	Mix 3	Mix 4	Mix 5	Ref. C	Mix 6	Mix 7	Mix 8	Mix 9	Mix 10
Low-alkali sulphate-resistant cement	312						266					
Aalborg White Cement		371	390	371	390	273		316	333	316	333	233
Fly ash	59						50					
White silica fume		20		20				17		17		
Silica fume	20						17					
Blast furnace slag						117						100
Zinc stearate				2	2					2	2	

Compressive strength adjusted to 6% air

1 day	7.4	25.7	25.7	25.9	22.0	11.6	8.2	4.9	19.8	14.1	18.6	13.2	7.8
2 days	19.1	44.1	48.7	41.4	39.6	26.9	16.8	11.2	33.4	24.6	32.6	24.0	14.4
7 days	38.6	57.9	60.5	51.2	49.5	41.0	34.0	24.6	43.7	36.0	43.9	32.9	23.3
14 days	50.1	66.6	63.5	57.0	54.8	48.8	43.1	31.9	51.7	40.7	50.6	36.0	28.8
28 days	64.0	70.7	69.0	67.0	57.3	57.1	54.7	42.4	53.1	47.1	58.5	39.9	35.0
90 days	71.7	77.4	76.6	70.0	67.2	64.0	56.5	55.0	60.6	54.7	65.9	49.5	41.6

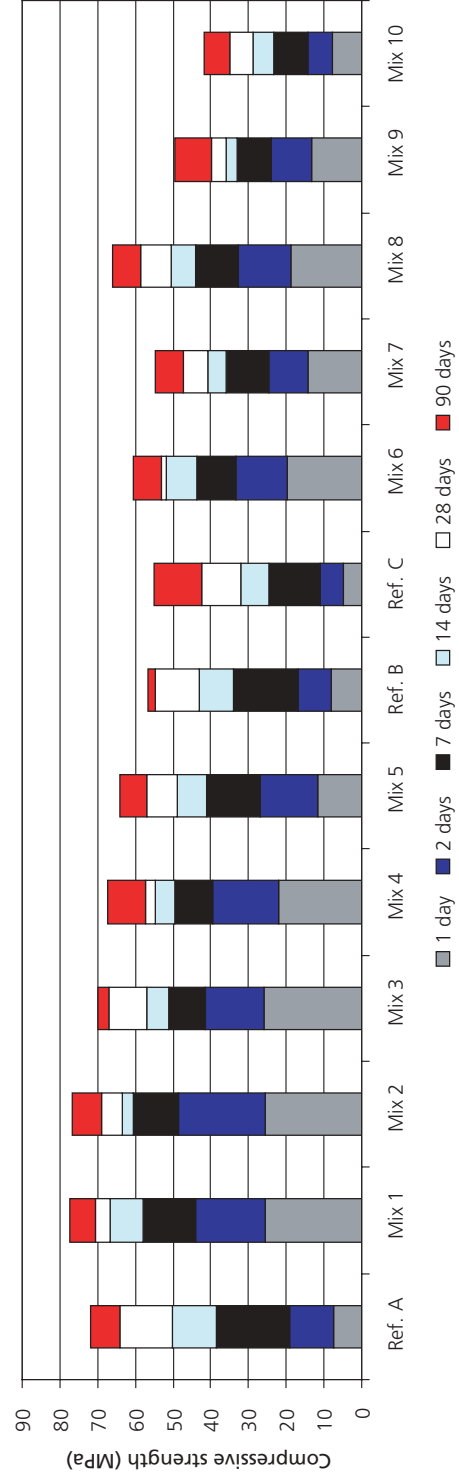



Appendix C: Splitting tensile strength

	Series 1, w/p - 0.36					Series 2, w/p - 0.45						
	Ref. A	Mix 1	Mix 2	Mix 3	Mix 4	Mix 5	Ref. C	Mix 6	Mix 7	Mix 8	Mix 9	Mix 10
Low-alkali sulphate-resistant cement	312						266					
Aalborg White Cement		371	390	371	390	273	316	333	316	316	333	233
Fly ash	59						50					
White silica fume		20		20				17		17		
Silica fume	20						17					
Blast furnace slag						117						100
Zinc sterate				2	2					2	2	

1 day	1.0	2.8	2.5	3.0	-	-	-	-	-	-	-	-
2 days	2.3	3.6	3.6	3.5	-	-	-	-	-	-	-	-
7 days	3.2	3.8	4.0	3.5	-	-	-	-	-	-	-	-
14 days	3.7	4.3	4.2	4.2	-	-	-	-	-	-	-	-
28 days	3.8	4.7	4.5	4.2	-	-	-	-	-	-	-	-

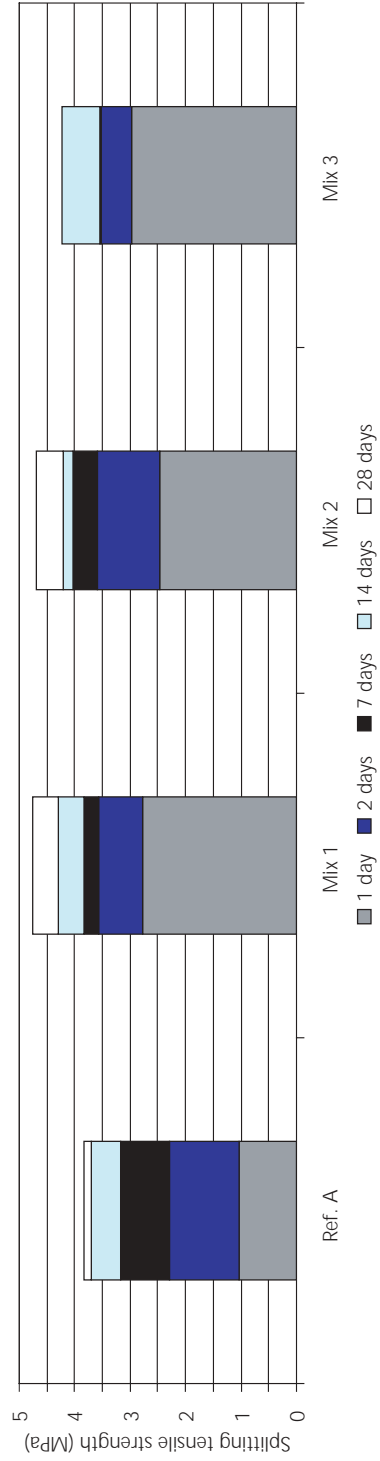



Appendix D: Modulus of elasticity

	Series 1, w/p - 0.36					Series 2, w/p - 0.45							
	Ref. A	Mix 1	Mix 2	Mix 3	Mix 4	Mix 5	Ref. B	Ref. C	Mix 6	Mix 7	Mix 8	Mix 9	Mix 10
Low-alkali sulphate-resistant cement	312						316	266					
Aalborg White Cement		371	390	371	390	273			316	333	316	333	233
Fly ash	59							50					
White silica fume		20		20					17		17		
Silica fume	20						17	17					
Blast furnace slag						117							100
Zinc stearate				2	2						2	2	

1 day	13.0	24.1	24.8	22.9	-	-	-	-	-	-	-	-	-
2 days	19.9	28.7	30.0	27.1	-	-	-	-	-	-	-	-	-
7 days	25.2	28.8	31.0	28.7	-	-	-	-	-	-	-	-	-
14 days	27.9	30.4	31.5	29.1	-	-	-	-	-	-	-	-	-
28 days	30.5	32.8	32.4	30.4	-	-	-	-	-	-	-	-	-

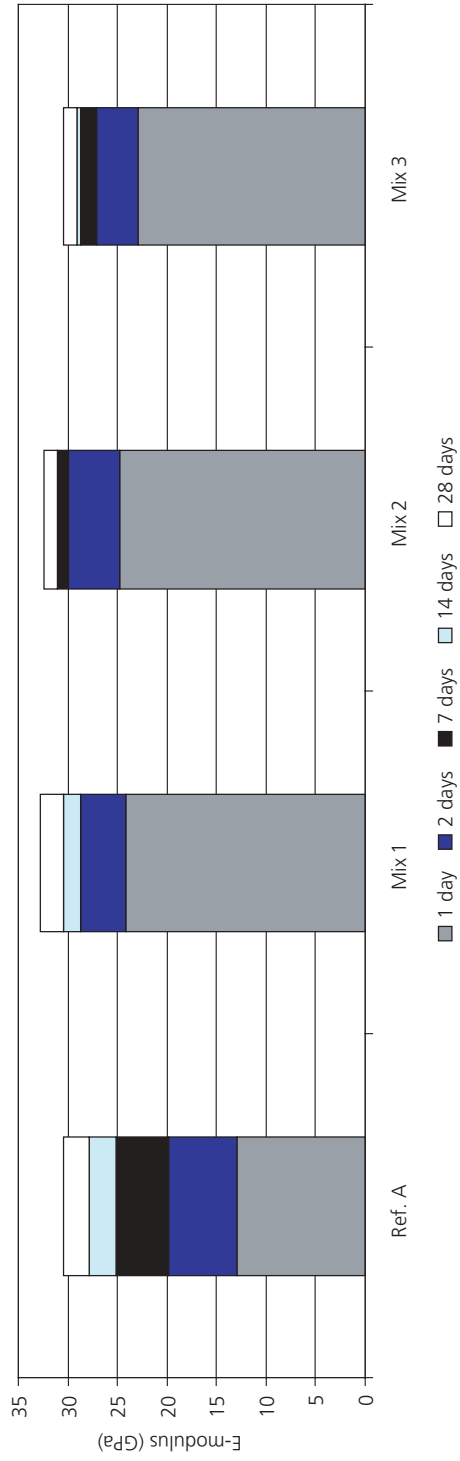



Appendix E: Frost testing to SS137244 and the analysis of thin sections

	Series 1, w/p - 0.36					Series 2, w/p - 0.4						
	Ref. A	Mix 1	Mix 2	Mix 3	Mix 4	Mix 5	Ref. C	Mix 6	Mix 7	Mix 8	Mix 9	Mix 10
Low-alkaline sulphate-resistant cement	312						266					
Aalborg White Cement		371	390	371	390	273		316	333	316	333	233
Fly ash	59						50					
White silica fume		20		20				17		17		
Silica fume	20						17					
Blast furnace slag						117						100
Zinc stearate				2	2					2	2	
7 cycles	0.01	0.00	0.00	0.01	0.01	0.02	0.03	0.03	0.07	0.02	0.00	0.37
14 cycles	0.02	0.01	0.01	0.02	0.01	0.02	0.03	0.03	0.12	0.03	0.01	0.77
28 cycles	0.04	0.02	0.01	0.02	0.02	0.03	0.05	0.03	0.14	0.05	0.01	1.13
42 cycles	0.04	0.02	0.01	0.03	0.03	0.03	0.07	0.04	0.15	0.07	0.04	1.35
56 cycles	0.09	0.02	0.02	0.05	0.04	0.05	0.07	0.04	0.15	0.08	0.08	1.52
Classification	VG	VG	VG	VG	VG	VG	VG	VG	G	VG	VG	UA
Specific surface	23.7	25.7	15.4	32.1	29.0	19.3	29.4	33.3	33.8	34.0	39.8	32.4
Spacing factor	0.19	0.17	0.27	0.14	0.16	0.24	0.13	0.13	0.13	0.15	0.11	0.14
Paste air content	17.0	18.3	20.5	16.9	17.5	15.7	23.0	17.6	17.9	13.7	19.8	17.9
Air content	5.7	6.1	6.8	5.5	5.7	5.1	7.8	5.6	5.7	4.2	5.8	5.7

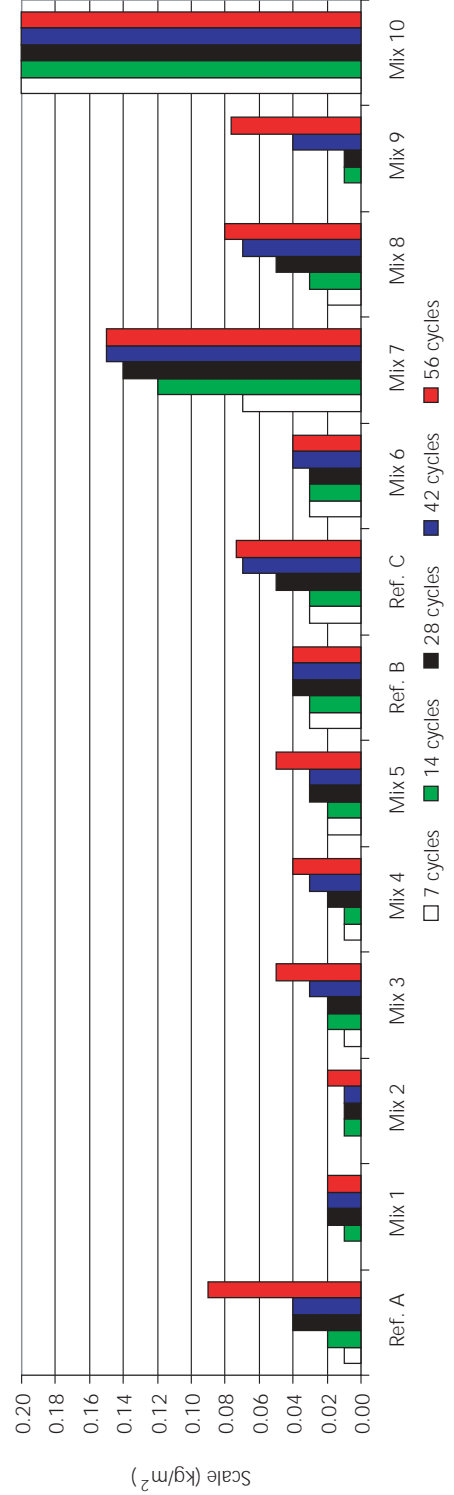



Appendix F: Chloride testing according to NT Build 492 (CTH method)

	Series 1. w/p - 0.36					Series 2. w/p - 0.45							
	Ref. A	Mix 1	Mix 2	Mix 3	Mix 4	Mix 5	Ref. B	Ref. C	Mix 6	Mix 7	Mix 8	Mix 9	Mix 10
Low-alkali sulphate-resistant cement	312						316	266					
Aalborg White Cement		371	390	371	390	273			316	333	316	333	233
Fly ash	59							50					
White silica fume		20		20					17		17		
Silica fume	20						17	17					
Blast furnace slag						117							100
Zinc stearate				2	2						2	2	

28 days	5.50	5.20	10.90	4.30	10.30	6.97	9.87	11.10	5.70	11.80	7.47	17.23	8.93
56 days	2.70	2.50	7.20	-	-	-	-	-	3.10	10.60	-	-	-
180 days	-	-	-	2.23	6.57	4.10	2.67	3.17	-	-	2.80	9.83	4.00

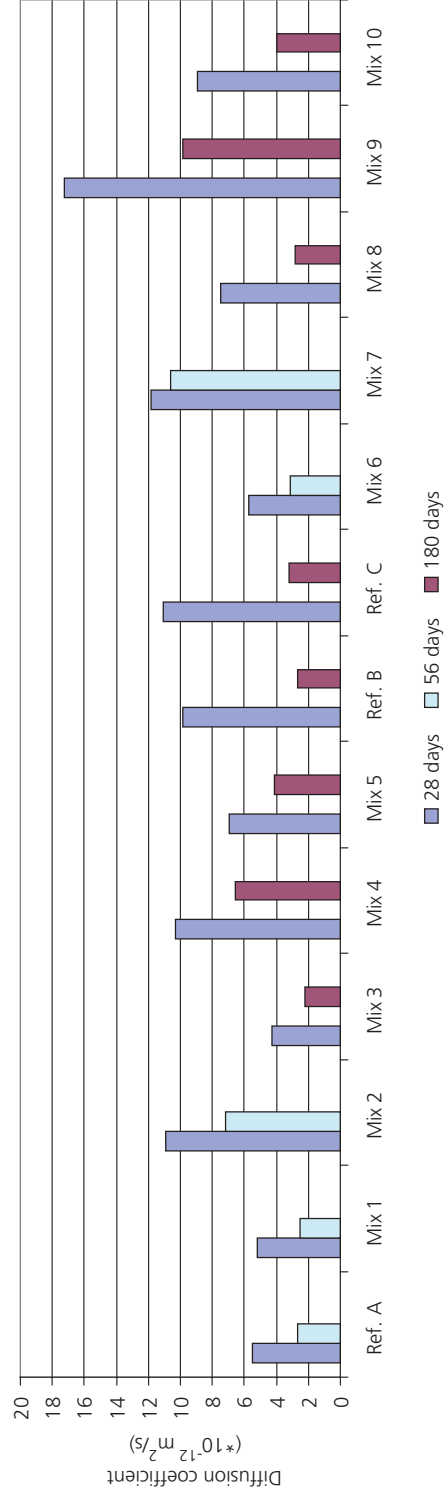



Appendix G: Chloride testing according to NT Build 443

	Series 1, w/p - 0.36					Series 2, w/p - 0.45							
	Ref. A	Mix 1	Mix 2	Mix 3	Mix 4	Mix 5	Ref. B	Ref. C	Mix 6	Mix 7	Mix 8	Mix 9	Mix 10
Low-alkaline sulphate-resistant cement	312						316	266					
Aalborg White Cement		371	390	371	390	273			316	333	316	333	233
Fly ash								50					
White silica fume		20		20					17		17		
Silica fume	20						17	17					
Blast furnace slag						117							100
Zinc sterate				2	2						2	2	

xx/yy = days of maturity before exposure/days of exposure

28/35	3.94	4.27	10.69	4.09	8.67	6.29	6.80	6.79	7.98	13.79	5.93	10.45	8.89
28/180	2.03	1.61	3.91	1.25	7.24	2.02	2.40	3.07	2.70	3.92	2.76	4.07	2.86

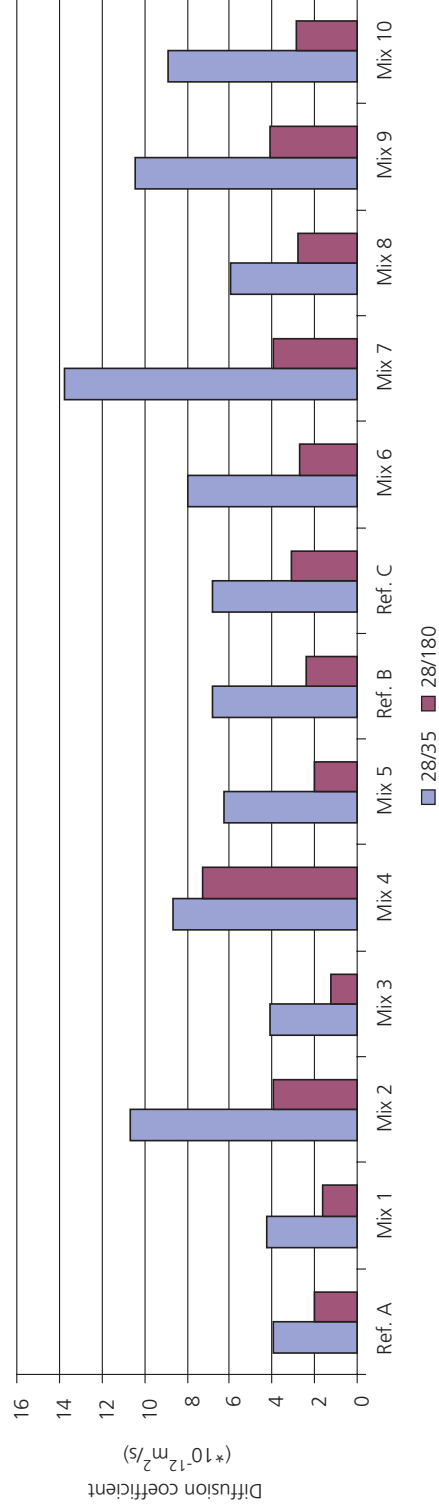



Appendix H: Adiabatic heat development

	Series 1. w/p - 0.36					Series 2. w/p - 0.45						
	Ref. A	Mix 1	Mix 2	Mix 3	Mix 4	Mix 5	Ref. C	Mix 6	Mix 7	Mix 8	Mix 9	Mix 10
Low-alkali sulphate-resistant cement	312						266					
Aalborg White Cement	59	371	390	371	390	273	50	316	333	316	333	233
Fly ash										17		
White silica fume	20	20		20								
Silica fume	20						17					
Blast furnace slag						117						
Zinc stearate				2	2					2	2	
Q_{∞}	266.4	312.5	305	316	309.3	279.4	321.5	338.3	326.9	325.1	324.4	286.3
τ_e	26.5	13.9	15.6	13.5	13.4	17.3	25.2	10.9	11.3	11.3	13.3	15.1
α	1.39	1.49	1.63	1.45	1.58	1.29	0.9	1.09	1.05	1.12	1.21	0.95

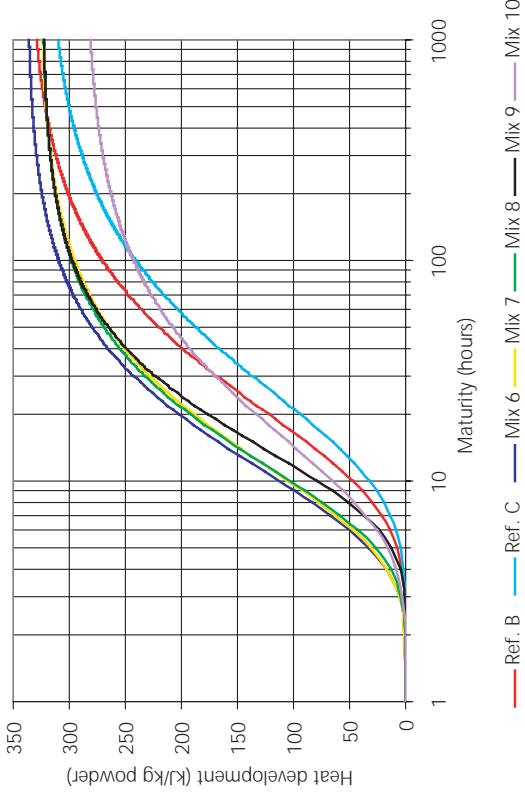
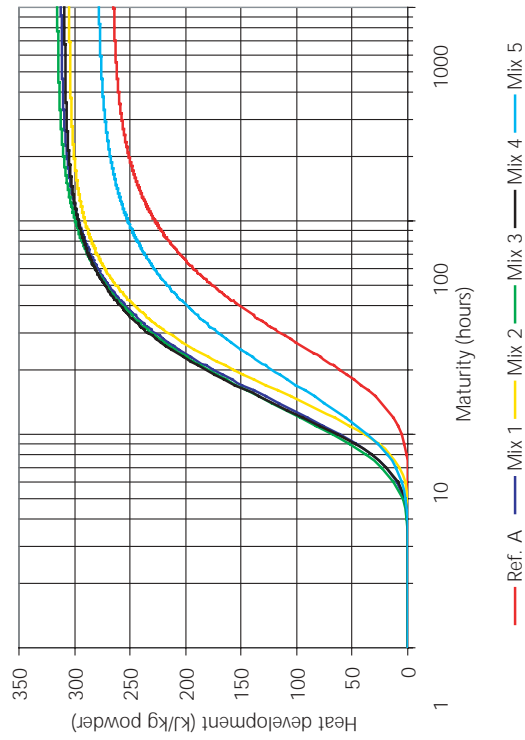



Appendix I: Chloride profiles according to NT BUILD 443

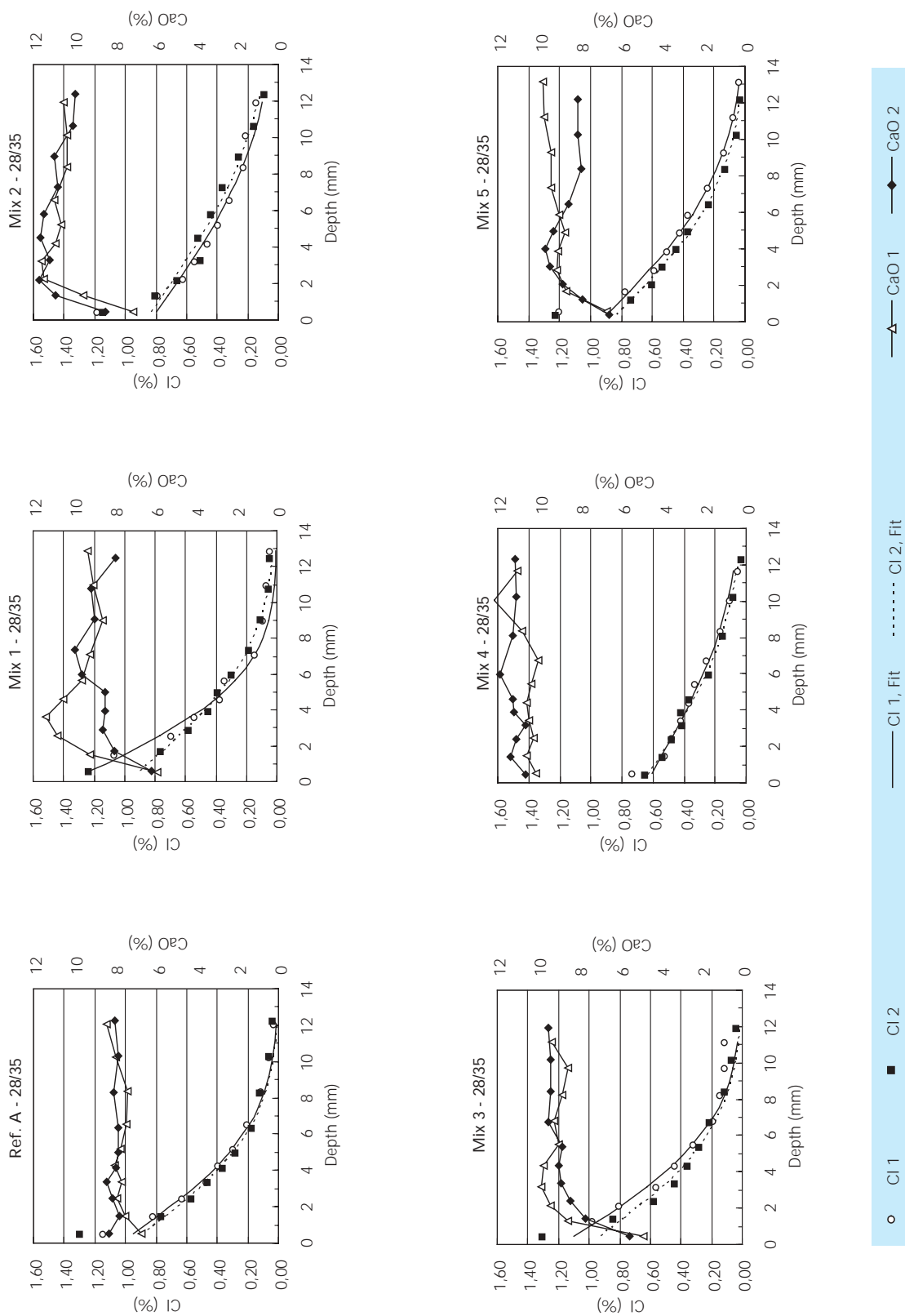



Appendix I: Chloride profiles according to NT BUILD 443

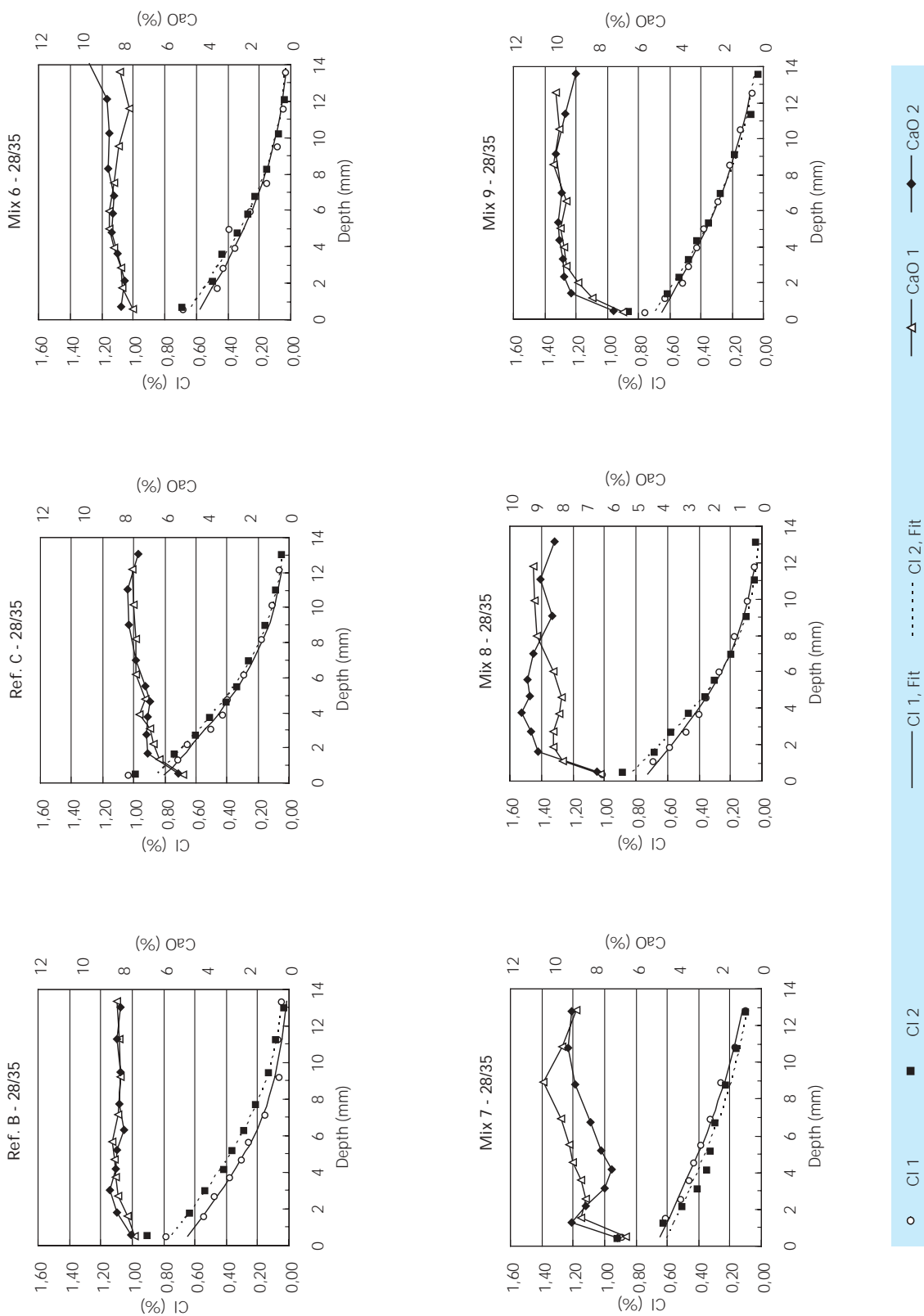



Appendix I: Chloride profiles according to NT BUILD 443

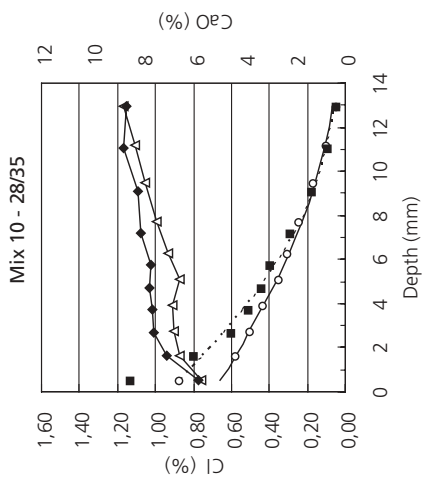



Appendix I: Chloride profiles according to NT BUILD 443

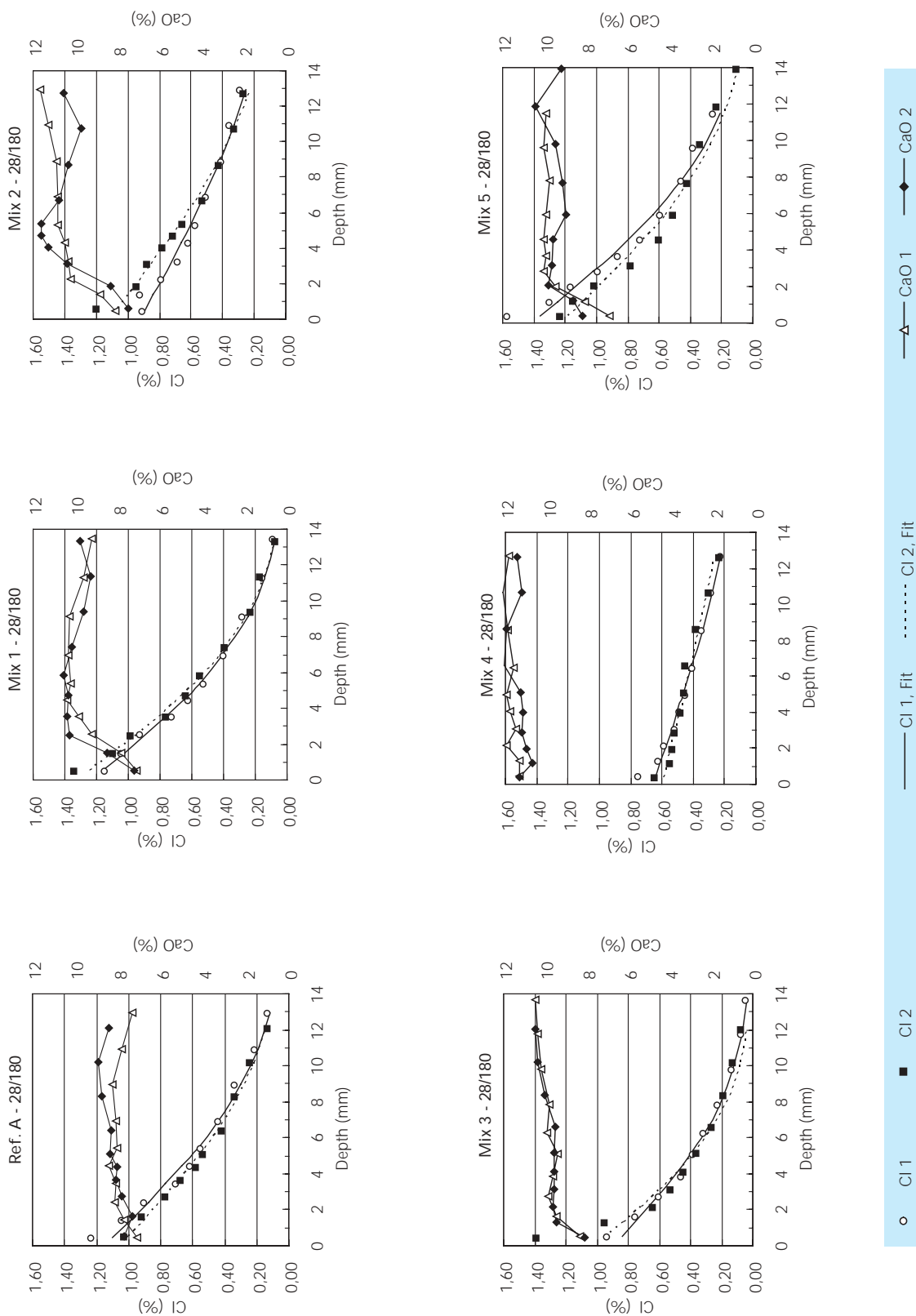



Appendix I: Chloride profiles according to NT BUILD 443

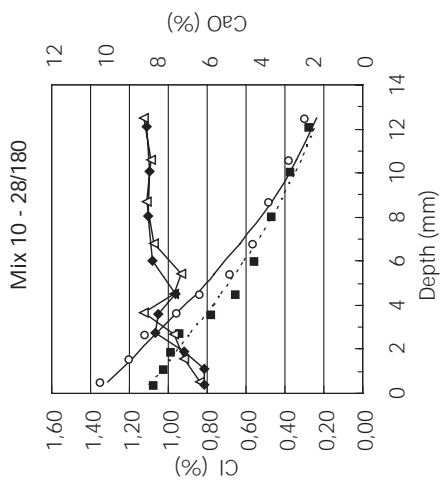



Appendix J: Data for materials used - Low-alkali Sulphate-resistant cement

Producer: Aalborg Portland
 Type: Low-alkali Sulphate-resistant Cement

Aalborg Portland Low-alkali Sulphate Resistant Cement

Type: Portland Cement, CEM I 42,5 N
 Strength Class: 42.5 N
 Sulphate resistance: HS
 Alkali content: EA
 Fineness (Blaine): 340 m²/kg

Density and Setting

Absolute density: 3200 kg/m³
 Bulk density: 1300 kg/m³
 Initial setting: 100 min.

More information on: www.aalborg-portland.dk

Cement composition - %

C ₃ S	C ₂ S	C ₃ A	C ₄ AF	Na ₂ O equiv.	CaSO ₄
53	30	4	7	0.34	2-3

Cement strengths - MPa (mortar prisms)

Cement strengths DS/EN 196-1	1 day	2 days	7 days	28 days
	9	18	36	58



Appendix J: Data for materials used - White Portland Cement

Producer: Aalborg Portland
 Type: White Portland Cement

Aalborg White Portland Cement - made in Denmark

Type: Portland Cement, CEM I 52,5 N
 Strength Class: 52.5 N
 Sulphate resistance: HS
 Alkali content: EA
 Fineness (Blaine): 410 m²/kg

Density and Setting

Absolute density: 3160 kg/m³
 Bulk density: 1100 kg/m³
 Initial setting: 100 min.

More information on: www.aalborg-portland.dk

Cement composition - %

C ₃ S	C ₂ S	C ₃ A	C ₄ AF	Na ₂ O eqv.	CaSO ₄
64	23	4	1	0.21	3-5

Cement strengths - MPa

Cement strengths	1 day	2 days	7 days	28 days
DS/EN 196-1	19	32	54	73



Appendix J: Data for materials used - Sand

Type:	Sand, Nørrehalne 0-2mm	
Particle size 02 (DS 405.9)	200 mm	
Sieve size:	Rest, g	Passing, %
Sieve, mm		
32	0.0	100
16	0.0	100
8	0.0	100
4	0.0	100
2	6.4	98
1	39.0	89
0.5	164.3	48
0.25	149.2	11
0.125	31.3	3
0.075	10.4	1
Bottom	3.6	
Total	404.2	
Initial weight	404.0	
Deviation %	0.0	
Density and absorption (DS 405.2)		
Density, saturated surface-dry	2635.0 kg/m ³	
Density, dry	2621.0 kg/m ³	
Absorption	0.5 %	



Appendix J: Data for materials used - Stone 2-8 mm

Type:	Stone, Espevig 2-8 mm	
Particle size (DS 405.9)	200 mm	
Sieve size:	Rest, g	
Sieve, mm	Rest, g	Contents of leight grains (DS 405.4)
32	0.0	> 2400 kg/m ³ 523.8 g
16	0.0	< 2400 kg/m ³ 0.0 g
8	20.3	< 2200 kg/m ³ 0.0 g
4	283.6	Total 523.8 g
2	119.6	
1	11.0	
0.5	3.2	
0.25	1.7	
0.125	2.2	
0.075	2.6	
Bottom	3.6	
Total	454.2	
Initial weight	454.1	
Deviation %	0.0	
		Density and absorption (DS 405.2)
		Density, saturated surface-dry 2637.0 kg/m ³
		Density, dry 2619.0 kg/m ³
		Absorption 0.7 %



Appendix J: Data for materials used - Stone 8-16 mm

Type:	Stone, Espevig 8-16 mm	
Particle size (DS 405.9)	300 mm	
Sieve size:	Rest, g	Passing, %
Sieve, mm		
32	0.0	100
16	67.1	89
8	450.7	12
4	45.9	5
2	0.0	5
1	0.0	5
0.5	0.0	5
0.25	0.0	5
0.125	0.0	5
0.075	0.0	5
Bottom	27.2	
Total	590.9	
Initial weight	590.4	
Deviation %	0.0	
Contents of leight grains (DS 405.4)		
	> 2400 kg/m ³	397.0 g
	< 2400 kg/m ³	0.5 g
	< 2200 kg/m ³	0.0 g
	Total	3997.5 g
Density and absorption (DS 405.2)		
	Density, saturated surface-dry	2624.0 kg/m ³
	Density, dry	2608.0 kg/m ³
	Absorption	0.6 %



Appendix J: Data for materials used - White silica fume

Producer:	Elkem	
Type:	White silica fume, 983 U	
SiO ₂	min.	98 %
C	max.	0.4 %
Fe ₂ O ₃	max.	0.05 %
Al ₂ O ₃	max.	0.3 %
CaO	max.	0.3 %
MgO	max.	0.1 %
K ₂ O	max.	0.25 %
Na ₂ O	max.	0.05 %
P ₂ O ₅	max.	0.1 %
SO ₃	max.	0.2 %
Cl	max.	0.01 %
H ₂ O	max.	0.3 %
Loss on Ignition (L.O.I)	max.	0.60 %
Coarse Particles; > 45 µm (325 mesh)	max.	0.2 %
pH-value (fresh)		5.0 - 6.0
Bulk Density (when packed)		300-450 kg/m ³



Appendix J: Data for materials used - Fly ash

Producer:	Nordjyllandsværket, Denmark	
Type:	Fly ash	
SiO ₂	%	48.75
Al ₂ O ₃	%	25.85
Fe ₂ O ₃	%	7.41
CaO	%	4.46
Fri CaO	%	0.15
SO ₃	%	0.81
Cl ⁻	%	0.070
æqv. Na ₂ O	%	2.59
Density	kg/m ³	2280
Activity index:		
28 days	%	89.7
90 days	%	103.0



Appendix J: Data for materials used - White Blast Furnace Slag

Type: White Grounded Granulated Blast Furnace Slag

SiO ₂	%	38.34
Al ₂ O ₃	%	5.94
Fe ₂ O ₃	%	0.43
CaO	%	39.85
MgO	%	12.40
LECO SO ₃	%	1.41
Grav. SO ₃	%	0.49
S--	%	0.37
Cl-	%	0.06
MnO	%	0.01
Mn	%	0.01
K ₂ O tot	%	0.49
Na ₂ O tot	%	0.48
Na ₂ O eqv.	%	0.80
TiO ₂	%	0.25
P ₂ O ₅	%	0.05
L.O.I	%	0.62
Density	kg/m ³	2900
Saturation	%	6.4
Hunter L	%	83.8
Reflection	%	70.2



Aalborg Portland A/S

Rørdalsvej 44
Postboks 165
DK-9100 Aalborg

Phone: +45 98 16 77 77
Fax: +45 98 10 11 86
E-mail: sales@AalborgWhite.dk
Website: www.AalborgWhite.com

AALBORG WHITE® is a trade mark registered by Aalborg Portland